

94082

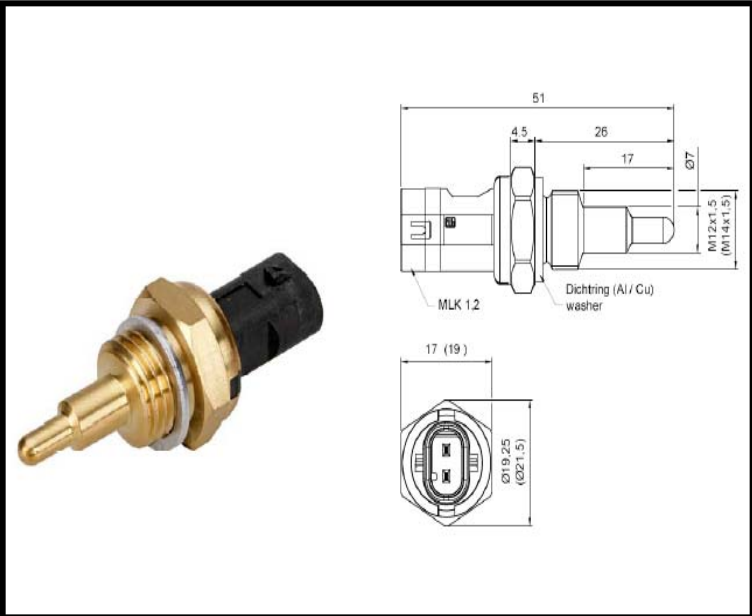

Benefits

The SSTS-9408 is a sturdy designed temperature sensor, that has proven sealing concepts, fast response times and they are 100% tested in production.

Applications

These sensors are suitable in a wide range of coolant, motor oil, fuel and liquid applications.

ELECTRICAL AND MOUNTING SPECIFICATIONS

Nominal Resistance	2.251 Ohm (25°C)*
Temperature Range	-40°C to +155°C
Time of Response	T90 < 10s (water)
Thread	M12x1.5
Connector	MLK 1.2
Sealing Ring	Al/cu
Protection Range	IP6K9K
Product Code	94082

*Other resistant values on request

<p>WARNING Personal Injury DO NOT USE these products as safety or Emergency Stop devices or in any other application Where failure of the product could result in Personal injury. Failure to comply with these instructions could Result in death or serious injury.</p>	<p>CAUTION Do not exceed maximum ratings. Although the sensor is protected against supply reversal, it is not recommended. Do not overtighten screw-in type. Do not use chlorinated solvents. Do not mount with dome pointing downwards. Failure to comply with these instructions may result in product damage.</p>
<p>It is the customer's responsibility to ensure that this product is suitable for use in their application. For technical assistance or advice, please email us: info@sstsensing.com</p>	